

**HOLLOW
METAL
MANUAL**



AMERICAN NATIONAL STANDARD

**ANSI/
NAAMM**

HMMA 863-24

**08 34 63.13 Steel Detention
Doors and Frames**

**GUIDE
SPECIFICATIONS FOR
DETENTION SECURITY
HOLLOW
METAL DOORS
AND FRAMES**

SEVENTH EDITION

XXXXXXXXXX XX, 2024



Approval of an American National Standard requires verification by ANSI that the requirements for due process, consensus, and other criteria for approval have been met by the standards developer.

Consensus is established when, in the judgment of the ANSI Board of Standards Review, substantial agreement has been reached by directly and materially affected interests. Substantial agreement means much more than a simple majority, but not necessarily unanimity. Consensus requires that all views and objections be considered, and that a concerted effort be made toward their resolution.

The use of American National Standards is completely voluntary; their existence does not in any respect preclude anyone, whether they have approved the standards or not, from manufacturing, marketing, purchasing, or using products, processes, or procedures not conforming to the standards.

The American National Standards Institute does not develop standards and will in no circumstances give an interpretation of any American National Standard. Moreover, no person has the right or authority to issue an interpretation of an American National Standard in the name of the American National Standards Institute. Requests for interpretation should be addressed to the sponsor whose name appears on the title page of this standard.

CAUTION NOTICE: This American National Standard can be revised or withdrawn at any time. The procedures of the American National Standards Institute require that action be taken periodically to reaffirm, revise, or withdraw this standard. Purchasers of American National Standards can receive current information on all standards by calling or writing the American National Standards Institute.

This standard was developed by representative members of the Hollow Metal Manufacturers Association (HMMA), a division of the National Association of Architectural Metal Manufacturers (NAAMM), to provide their opinion and guidance on the specification and use of detention security hollow metal doors and frames. This standard contains advisory information only and is published as a public service by NAAMM and its HMMA Division.

NAAMM AND ITS HMMA DIVISION DISCLAIM ALL LIABILITY OF ANY KIND FOR THE USE, APPLICATION, OR ADAPTATION OF MATERIAL PUBLISHED IN THIS STANDARD.

Current information on all NAAMM Standards is available by calling, writing or visiting the website of the National Association of Architectural Metal Manufacturers, www.naamm.org.

National Association of Architectural Metal Manufacturers
800 Roosevelt Rd. Bldg. C, Suite 312, Glen Ellyn IL 60137
www.naamm.org

Copyright © 1985, 1987, 1990, 1998, 2005, 2014, 2024 National Association of Architectural Metal Manufacturers All Rights Reserved

TABLE OF CONTENTS

Introduction.....	ii
Foreword.....	vii

Part 1 – GENERAL

1.01 Summary.....	1
1.02 Products Provided Under This Section	1
1.03 Related Sections.....	1
1.04 References.....	2
1.05 Testing and Performance	3
1.06 Quality Assurance.....	4
1.07 Submittals	4

Part 2 – PRODUCTS

2.01 Detention Security Hollow Metal Doors.....	5
2.02 Detention Security Hollow Metal Panels	8
2.03 Detention Security Hollow Metal Frames	8
2.04 Manufacturing Tolerances	12
2.05 Hardware Locations	14
2.06 Finish	15

Part 3 – EXECUTION

3.01 Site Storage and Protection of Materials.....	16
3.02 Installation	17
3.03 Clearances.....	19
3.04 Job Site Door Check	20

APPENDICES (Not part of the Standard)

Appendix 1 / HMMA-803, Steel Tables.....	A1
Appendix 2 / HMMA-820 TN01, Grouting Hollow Metal Frames	A2
Appendix 3 / HMMA-810 TN01, Defining Undercuts.....	A3
Appendix 4 / Standards Development Organizations	A5

INTRODUCTION

HOLLOW METAL DETENTION SECURITY SYSTEMS

Detention security hollow metal doors and frames have been successfully used in detention and correctional facilities throughout the world. Architects, specifiers, and end users understand the advantages of using Detention Security Hollow Metal in these applications.

HARDWARE INSTALLATION AND MAINTENANCE

To understand the advantages of hollow metal construction, consider first the hardware installation for the swinging door of a typical bar-grille cell front. The security hinges and lock encasement are actually accessible to the inmate since he is able to reach through the bars. Therefore, in many cases, the lock encasement must be continuously welded assemblies with cover plates welded in place to prevent inmate tampering. This situation makes repairs and maintenance both difficult and expensive. For example, to repair a lock it is necessary to cut the cover plate loose with a torch, repair or replace the lock, then weld a new cover plate back in place.

In the hollow metal assembly, the lock is mounted in a reinforced pocket, inside the door or frame and is protected by a heavy gauge cover plate fastened with security screws. The flush type detention hollow metal door, examples shown in Figure 1, severely limit the inmate's access and visibility in any attempts to tamper with the cover plate and lock. Since inmate tampering is limited by the flush hollow metal design, cover plates and access panels can be mounted with tamper resistant screws in most cases rather than welding, thereby reducing the cost of installation, repair, and maintenance.

HOLLOW METAL VERSUS BAR-GRILLE CONSTRUCTION

Bar-grille assemblies are manufactured by a variety of methods. However, regardless of the method used, the end result must be an assembly, which has been "hardened" against attack or tampering. By its design, bar-grille allows access by the inmate to the outside of the enclosure and thereby access to lock and position switch encasement, as well as conduit casements. Also, the bars themselves must be made resistant against tool attack, again because they are accessible to the inmate. The security of bar-grille assemblies is accomplished by various means depending upon the manufacturer's philosophy and methods; however, the bottom line is that the heavy material, heat treating processes, and assembly processes necessary are expensive.

On the other hand, consider typical detention hollow metal assemblies as shown in Figure 1. The frame is fabricated of pressed steel sections with integral doorstops and is fully grouted after installation. It is prepared for the appropriate security hardware including conduit routed internally, junction boxes and access openings with cover plates as necessary for wiring installations. The door can be a typical detention security type, prepared for security hinges, electrical or mechanical detention security lock, and position switch indicator. The door preparation can include conduit routed internally to suit electrically operated hardware when applicable. When confined, the inmate has no access to the outside of the enclosure because there are no grille openings except where desired in the design. This means that security can be obtained by limited accessibility to sensitive areas of the opening such as locks, hinges and position indicators. Heat treatment is not required for the steel used in the detention hollow metal construction. Because of the materials and manufacturing processes used, the hollow metal construction costs in most cases are considered economical.

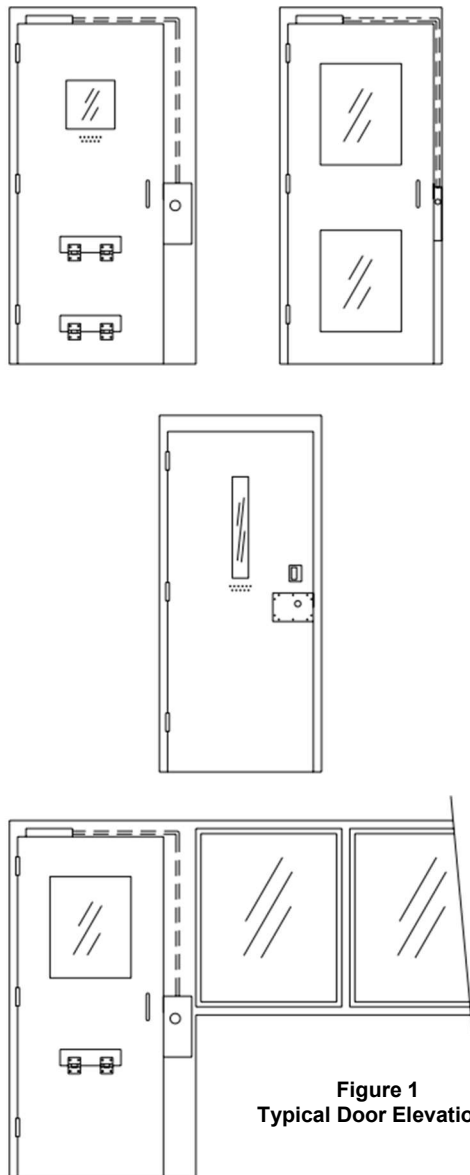

**Figure 1
Typical Door Elevations**

SAFETY, SECURITY, AND WELFARE

The safety, security, and welfare of staff, as well as inmates, are enhanced by hollow metal construction. In the typical bar-grille cell front, the inmate not only has access to all of the hardware, as mentioned previously, but also has numerous opportunities to abuse or injure a staff member or other inmates by throwing objects or bodily fluids or by grabbing them through the bars. Blood and fluid borne diseases such as tuberculosis and the HIV virus accentuate this risk. Although the installation is secure, the dangers to people passing by in corridors are still considerable. When bar grille is used, corridors often must be wider to help minimize these problems. Also, bar installations do not inhibit an inmate from rattling the door, clanging the bars and generally making life miserable for other inmates and staff.

The advantages of the hollow metal cell front are evident. As shown in Figure 1, there are no openings through which an inmate can reach and harm passers-by. The only openings are staff-controlled openings, such as a food-pass. The reduction of visibility, which can occur in a hollow metal assembly, is offset by the proper placement of security glass, perforated plate, wire mesh screen or grille. Any combination of these options can be incorporated into a hollow metal door or frame to provide adequate visibility for the purpose of staff observation. Cell fronts can be designed using side-light frames for better visibility into cells.

Caution: It is not advisable to locate glass preparations in close proximity to hardware preparations at the door edge since this can be detrimental to door stiffness.

The door construction itself also reduces, even though it cannot completely eliminate, the opportunity for making noise and creating a disturbance. Because of the internally stiffened, insulation filled construction of the door, the inmate will only be able to make a dull, thudding noise if he chooses to beat and kick the cell front. Also, the full grouted jambs and mullions are highly effective for noise control.

DESIGN VERSATILITY WITH HOLLOW METAL

Hollow metal construction provides the Architect with a great deal of freedom in the design of cell fronts as well as security window walls, guard enclosures and control stations while keeping costs within reasonable limits. The Architect can also take advantage of the expertise acquired by those hollow metal manufacturers who have had experience in detention security work. Over the years NAAMM/HMMA manufacturers have developed advanced methods and equipment enabling them to efficiently manufacture hollow metal assemblies, which address today's difficult detention applications. These applications include working with the latest in electronic hardware, security glazing and detention screening. A number of these manufacturers offer proven economical and functional designs of their own for cell fronts, hardware preparations, security windows with shutters, vision panels, security vent grilles, speaking devices, food passes, access doors, sound retardant doors and panels, observation windows and gun ports, hollow metal wall systems, and other items. Some manufacturers also have the capability of producing heavy-duty prison furniture such as cell bunks, desks, shelves, mess hall tables, benches, etc. Typical security window and guard control station installations are shown in Figures 2 and 3 respectively.

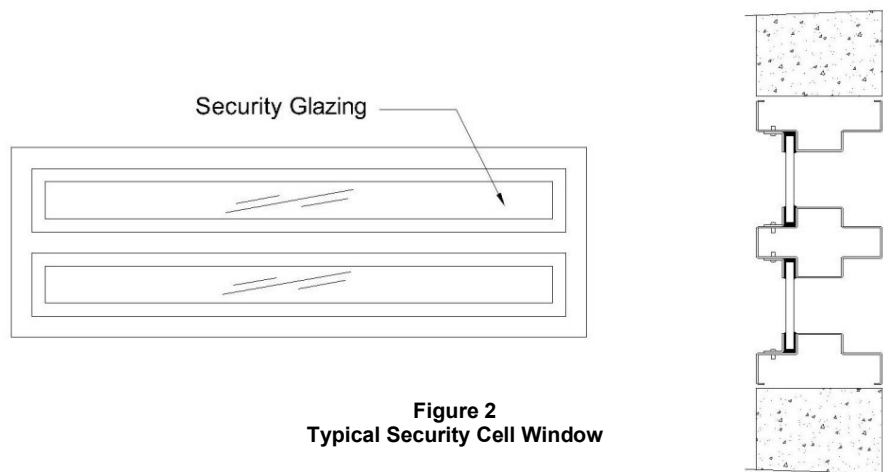

Figure 2
Typical Security Cell Window

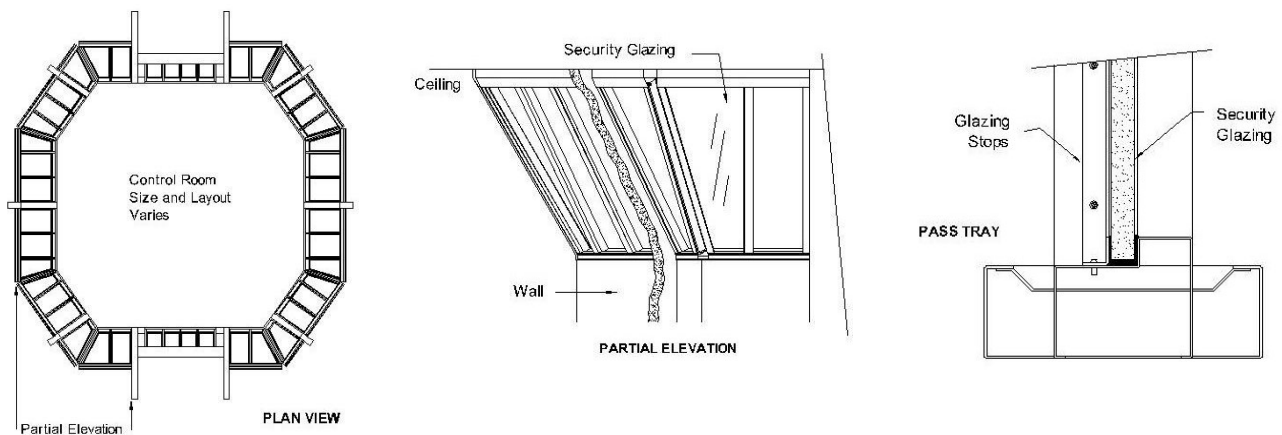

Figure 3
Typical Control Room Details

EVALUATING DETENTION SECURITY DOORS

In order to evaluate the performance of detention security doors it has been necessary to develop testing methods which simulate in the laboratory the use and abuse to which such doors can be subjected when in use in correctional facilities. One objective of this development work is to provide standardized methods of measuring performance, which the Architect can call for in their specifications. Another objective is to provide manufacturers standardized means of testing and inspecting their products, improving their designs, and maintaining high quality construction. Finally, maintenance of rigorous standards and methods of testing construction and performance give assurance of protection to the public, the prison employees, and the inmates themselves. The performance requirements and methods of testing set forth in this voluntary standard should go a long way towards realizing the stated objectives.

TESTING

Six tests are required by this specification, which are conducted in accordance with ASTM F 1450, "Standard Test Methods for Hollow Metal Swinging Door Assemblies for Detention Facilities", and ASTM F 1592, "Standard Test Method for Detention Hollow Metal Vision Systems".

- A. Door Assembly Impact Load Test – ASTM F 1450
- B. Sidelight and Multi-Light Assembly Impact Test – ASTM F 1592
- C. Door Static Load Test – ASTM F 1450
- D. Door Rack Test – ASTM F 1450
- E. Door Edge Crush Test – ASTM F 1450
- F. Bullet Resistance Test – ASTM F 1450, ASTM F 1592 & UL-752

Under the **static load and rack tests** a completely fabricated door, including hardware and vision light, is subjected to specified loads. In the case of the **static load test** the performance standard requires that the door not exceed a specified maximum deflection when a specified load is centrally applied at the quarter points of the door. In the case of the **rack test**, one corner of the door is left unsupported and must not exceed a specified maximum deflection when a specified concentrated load is applied at the unsupported corner.

Static load and rack tests are prerequisites to all other testing. They provide the basis for checking integrity of construction methods, quality of welds, strength of materials and rigidity of the door assembly. However, these two tests alone are not considered adequate measurements of performance. The **static load test** does not simulate the punishment a door can receive when it is installed in a prison. It only evaluates how well the door performs as a simply supported beam. The **rack test** does evaluate the resistance of a door to end torque, which provides some indication of the ability of the door to resist an attempt to pry open the door at the top or bottom corner. Furthermore, the two tests lead one to believe that the greater the rigidity the better the performance. This can be misleading in as much as there are definite performance advantages associated with the qualities of limited flexibility and resilience in a door exposed to field conditions. So, while these two tests are valuable in the evaluation of the basic design and construction, additional testing is needed to better evaluate how the door will perform under conditions which can occur in a prison.

The **impact load test** provides a much more realistic measure of a door's ability to withstand the treatment it can receive under riot conditions. For this test a door complete with hardware is mounted in its frame with the entire assembly in the vertical position so that the door and locking hardware are operable. The door is then subjected to a series of impact loads from a pendulum ram. The repetitive impact load specified in this standard was established by experimentation that determined what a person with a sledgehammer or several persons with a battering ram could develop in the way of impact energy per blow. From consultations with prison officials the time usually required to restore order in a major riot situation was ascertained. It was assumed that a person or persons could assault a door throughout this period of time and based on this assumption the total number of impacts to which the door would be subjected was determined. Upon completion of the impact testing, it is required that the door still be operable. This is indeed a rigorous test and one which when added to the bullet resistance test gives a good indication as to the performance, which can be expected of a door under riot conditions. The sidelight, window and multi-light tests are also done with impact loads. Their purpose is to assure that the frame construction and the removable glass stops used in the frame, are at least equal to the strength of the doors and security glazing they support.

The **bullet resistance test** is conducted in accordance with UL Standard 752,[see Table 1 for comparison of associated tests]. In this test a super power rated handgun is used. A rifle, which is more powerful than a handgun is not addressed because the possibility of an inmate obtaining a rifle is very remote, and a rifle is more difficult to conceal and smuggle into public or secure areas. The term “bullet-resisting” as used in the UL standard signifies protection against complete penetration, passage of fragments of projectiles, or spalling (fragmentation) of the protective material to the degree that injury would be caused to a person standing directly behind the bullet-resisting barrier.

Edition 11	Edition 12
Current UL752 – Level 3	New UL 752 – UL-HG-C
.44 Mag	.44 Mag (Same)
240 Grain	240 Grain (Same)
1350 fps Velocity	1430 fps Velocity (Increased)
3 Shots	3 Shot Triangle
	2 Shot
	Combined shot equals 5 die pattern (Different)
	Additional unsupported edge shot
	Minimum number of samples (3)

Table 1
Testing comparison UL 752 – Editions 11 and 12

CONSTRUCTION

The parts of this standard which cover construction specify the types of steel to be used and the minimum acceptable thickness for different applications. The products covered are doors, frames, fixed windows, hardware reinforcements, glass moldings and stops, louvers, speaking devices, food pass openings, floor anchors, jamb anchors, plaster guards, and removable glazing stops. Construction requirements are very prescriptive and describe how doors can be welded, how stiffeners can be formed and fastened to the face sheets, how vertical edges can be reinforced, what is required for top and bottom closing channels and how they can be welded, and what can be used for hardware reinforcements and how such reinforcements can be applied. The same kind of detailed prescriptive requirements are given for all of the other products covered. This has been done to provide the Architect with designs for detention security products, which have been proven by testing and by historical performance in correctional facilities. Such prescriptive requirements are not intended to restrict innovative design, but NAAMM recommends that any alternative construction be subjected to the performance and testing requirements set forth in this standard before being accepted for detention security installations.

CONCLUSION

This standard will prove very useful to architects concerned with the design of correctional facilities. NAAMM members who manufacture detention security hollow metal products stand ready to assist Architects in their design and specification of these products. Send questions and/or comments on this standard to the NAAMM office.

FOREWORD

These specifications have been prepared in accordance with CSI Section Format: Part 1 - General, Part 2 Product and Part 3 - Execution. Guide specifications are intended to be used as the basis for developing job specifications and must be edited to fit specific job requirements. Inapplicable provisions are to be deleted, appropriate selections are made where there are choices, and provisions applicable to the job are added where necessary. Optional items or requirements are shown in brackets. **Notes and instructions to specifiers are given in italics directly following the paragraphs to which they apply. Notes that contain permissive language are not considered part of the standard.** Dates given with ASTM and other standards were current at the time this specification was published, and define the specific standards referenced herein. When a more recent standard is available, the specifier should verify its applicability to this guide prior to its inclusion. *While the CSI Section Format locates Delivery, Storage, and Handling in Part 1, NAAMM Standards include them under Part 3 – Execution.*

Materials and fabrication methods are specified in detail in Part 2. Doors and frames made in accordance with these specifications have successfully met the testing and performance requirements of Section 1.05. However, the materials and fabrication methods called for in these specifications, while providing a sound guide, are not meant to restrict the use of other materials and methods where it can be demonstrated through the specified testing procedures in Section 1.05 that the construction can equal or exceed the performance levels specified in this section. In order to ensure that a manufacturer's product meets the desired performance levels, the project specifications include the testing and performance requirements of Section 1.05 and the Quality Assurance requirements of Section 1.06. The values stated in inch-pound units are to be regarded as the standard. Corresponding metric values are included in parentheses for reference purposes only.

Security grades were added in the 5th Edition in response to input from members of the architectural community, particularly those who are regularly involved in the design of Detention and Correctional Facilities and are also involved in ASTM standards development efforts for these facilities. The four (4) security grade levels cited in the specification refer not only to the HMMA performance requirements for detention hollow metal, but also to related ASTM standards that have been recently developed for detention hollow metal, locks, and sliding door devices. These grade levels provide a quick reference to performance standards outside HMMA, which are coordinated with this HMMA specification and can be easily used when writing project specifications.

This standard indicates both CSI Section 11 19 00 or 08 34 63.13 for detention security hollow metal doors and frames.

CSI SECTION 08 34 63.13† - DETENTION SECURITY HOLLOW METAL DOORS AND FRAMES

PART 1 - GENERAL

1.01 SUMMARY

This Section includes detention security hollow metal [bullet resistant] products as shown in the contract documents and as specified herein.

1.02 PRODUCTS PROVIDED UNDER THIS SECTION

- A. Detention security hollow metal [bullet resistant] doors with [3 hour] [1½ hour] [¾ hour] [⅓ hour] fire rating, [swinging type] [and/or] [sliding type] as shown in the approved submittal drawings and as specified herein.
- B. Detention security hollow metal [bullet resistant] doors include [glass molding and stops] [louvers] [speaking devices] [food pass openings] [other] as shown in the approved submittal drawings and specified herein.
- C. Detention security hollow metal [bullet resistant] panels with [3 hour] [1½ hour] [¾ hour] [⅓ hour] fire rating of the same construction as the detention security doors.
- D. Detention security hollow metal [bullet resistant] [and/or] [fire rated] frames for [3 hour] [1½ hour] [¾ hour] [⅓ hour] fire rating with anchors. Transom frames, side-light, multi-light, and window assemblies, including [glass moldings and stops] [louvers] [hollow metal panels] [other], as shown in the approved submittal drawings.
- E. Detention security hollow metal [bullet resistant] frames include [speaking devices] [pass thru devices] [gun ports] [other] as shown in the approved submittal drawings and specified herein.

Indicate bullet resistant doors, frames and panels only if applicable to the job. If these are to be fire-rated doors, frames and panels, indicate the required rating for each: 3 hour, 1-1/2 hour, ¾ hour, or ⅓ hour. Also, indicate the type of door operation required (swinging and/or sliding), those items in 1.02.B which are to be included with the doors, and those items in 1.02.D & E which are included with the frames.

1.03 RELATED SECTIONS

- A. Section 03 30 00 - - - - Cast in Place Concrete: Item(s)
- B. Section 03 35 00 - - - - Concrete Finishing: Item(s)
- C. Section 03 40 00 - - - - Pre-cast Concrete: Item(s)
- D. Section 04 20 00 - - - - Unit Masonry System: Item(s)
- E. Section 05 12 00 - - - - Structural Steel Framing: Item(s)
- F. Section 08 11 13 - - - - Hollow Metal Doors and Frames
- G. Section 08 34 53 - - - - Security Doors and Frames
- H. Section 08 11 19 - - - - Stainless Steel Doors and Frames
- I. Section 08 34 73 - - - - Sound Control Doors Assemblies
- J. Section 08 56 00 - - - - Special Function Windows
- K. Section 08 71 00 - - - - Door Hardware
- L. Section 08 74 00 - - - - Access Control Hardware: Item(s)
- M. Section 08 88 53 - - - - Security Glazing
- N. Section 09 90 00 - - - - Painting and Coating: Item(s)
- O. Section 08 71 63 - - - - Detention Door Hardware
- P. Section 11 19 00 - - - - Detention Equipment (†)

Not included in section 11 19 00 (08 34 63.13) are installation of doors, frames, panels, door hardware or rough hardware of any kind, weather-stripping, gasketing, operable windows, items furnished by others, field painting, or protection at the building site of products furnished under this Section.

1.04 REFERENCES

The publications listed in this section form a part of this specification to the extent referenced in the specification text. The publications are referenced in the text by basic designation only. When a more recent standard is available, the specifier should verify its applicability to this Guide prior to its inclusion.

- A. ANSI / SDI A 250.10, Standard Test Procedure and Acceptance Criteria for Prime Painted Steel Surfaces for Steel Doors and Frames
- B. ANSI / NAAMM HMMA 801, Glossary of Terms for Hollow Metal Doors and Frames
- C. ANSI / NAAMM HMMA 866, Guide Specifications for Stainless Steel Hollow Metal Doors and Frames
- D. ANSI / NFPA 80, Standard for Fire Doors and Other Opening Protectives
- E. ANSI / NFPA 105, Standard for Smoke Door Assemblies and Other Opening Protectives
- F. ANSI / NFPA 252, Standard Methods of Fire Tests of Door Assemblies
- G. ANSI / NFPA 257, Methods for Fire Test of Window Assemblies
- H. ANSI / UL 9, Fire Tests of Window Assemblies

- I. ANSI / UL 10C, Standard for Positive Pressure Fire Tests of Door Assemblies
- J. ASTM A 653 / A 653M, Specification for Steel Sheet, Zinc-coated (Galvanized) or Zinc-Iron Alloy-Coated (Galvannealed) by the Hot Dipped Process, (Commercial Steel)
- K. ASTM A 666, Standard Specification for Annealed or Cold-Worked Austenitic Stainless Steel Sheet, Strip, Plate and Flat Bar.
- L. ASTM A 1008 / A 1008M, Specification for Steel, Sheet, Cold-Rolled, Carbon, Structural, High-Strength Low-Alloy and High-Strength Low-Alloy with Improved Formability
- M. ASTM A 1011 / A 1011M, Specification for Steel, Sheet and Strip, Hot-Rolled, Carbon, Structural, High-Strength Low-Alloy and High-Strength Low-Alloy with Improved Formability
- N. ASTM C 143 / C 143M, Standard Test Method for Slump of Hydraulic Cement Concrete
- O. ASTM F 1450, Standard Test Methods for Hollow Metal Swinging Door Assemblies for Detention and Correctional Facilities.
- P. ASTM F 1592, Standard Test Methods for Detention Hollow Metal Vision Systems
- Q. CAN/ULC-S104, Standard Method for Fire Tests of Door Assemblies
- R. CAN/ULC-S106-15, Standard Method for Fire Tests of Window and Glass Block Assemblies
- S. NAAMM HMMA 803, Steel Tables
- T. NAAMM HMMA 810, Hollow Metal Doors
NAAMM HMMA 810 TN01 Defining Undercuts of Doors
- U. NAAMM HMMA 820, Hollow Metal Frames
NAAMM HMMA-820 TN01 Grouting Hollow Metal Frames
NAAMM HMMA 820 TN02, Continuously Welded Frames

- V. NAAMM HMMA 840, Installation and Storage of Hollow Metal Doors and Frames
- W. NAAMM HMMA 850-00, Fire-Rated Hollow Metal Doors and Frames
- X. UL 752, Bullet Resisting Equipment

Refer to Appendix 4 for a list of the Standards Writing or Accreditation Organizations referenced in Section 1.04.

1.05 TESTING AND PERFORMANCE

A. Conduct testing on all door, frame and vision system samples as required by the following standards:

1. Door Static Load, Door Rack Test, Door Impact, Door Edge Crush, and Door Bullet Penetration in accordance with ASTM F 1450 and UL 752.
2. Vision System Impact Test in accordance with ASTM F 1592.

Refer to the contract documents for the "Security Grade" number required for each detention hollow metal opening.

B. Labeled Fire Rated and/or Smoke Control Doors and Frames

1. Provide doors, frames, transom frames and sidelight assemblies for openings requiring fire protection, temperature rise, and/or smoke and draft control which are listed and/or classified and bear the label of a testing agency having a factory inspection service. Test the products in accordance with, [ANSI/NFPA-252 or CAN/ULC-S104] [ANSI/UL-10C] [UL 1784 or ANSI/NFPA 105] and constructed as listed and/or classified for labeling. The architect determines and schedules the fire, temperature rise, and/or smoke and draft control ratings.
2. Provide window frames for openings requiring fire protection ratings which are listed and bear the label of a testing agency having a factory inspection service. Test frames in accordance with [ANSI/NFPA 257 or ANSI/UL 9] and construct frames as listed for labeling. The architect determines and schedules fire and/or smoke and draft control ratings.

UL 10C provides for positive pressure testing to accommodate the requirements of some jurisdictions and should be included only for such jurisdictions.

UL 1784, and ANSI/NFPA 105 provide for smoke and draft control assembly testing to accommodate these specific requirements and should be included only when required.

Include CAN-S104 and CAN-S106 only for projects requiring conformance with Canadian Building codes.

3. Advise the architect in the submittal documents if any door or frame product specified to be fire-rated cannot qualify for labeling because of design, hardware, or any other reason. Advise the architect of label conflicts arising from hardware, glazing, or other options that were unknown at time of submittal document preparation.

For additional information, refer to NAAMM HMMA 850 "Fire-Rated Hollow Metal Doors and Frames".

C. Prime Paint Performance (ANSI A250.10)

1. Test sheet steel specimens, with the product manufacturer's production primer, replicating Finish 'as shipped', in accordance with ANSI A250.10.
2. Meet acceptance criteria described in ANSI A250.10.

3. Include a description of the test specimens, procedures used in testing in independent third-party test reports and Certificates of Compliance, and indicate compliance with the contract documents' specified acceptance criteria.

1.06 QUALITY ASSURANCE

A. Manufacturer's Qualification

Provide evidence of having personnel and plant equipment capable of fabricating hollow metal door and frame assemblies of the type specified herein.

Provide evidence of having a written quality control system in place.

B. Quality Criteria

With regard to all door and frame construction, meet the requirements of Section 1.05 of these specifications. Fabricate assemblies in strict accordance with approved submittal drawings.

With regard to fabrication methods and product quality, meet standards set by the Hollow Metal Manufacturers Association, HMMA, a Division of the National Association of Architectural Metal Manufacturers, NAAMM, as set forth in these specifications.

1.07 SUBMITTALS

A. Submittal Drawings

1. Show door and frame elevations and sections.
2. Show listing of opening descriptions including locations, material thicknesses, and anchors.
3. Show location and details of all openings.

Indicate performance grade levels on the submittal as they are shown on the contract documents.

B. Samples (if required)

Door: 1 ft. x 1 ft. (305 mm x 305 mm) corner section with hinge mortise and reinforcement showing internal construction.

Frame: 1 ft. x 1 ft. (305 mm x 305 mm) corner section showing welding of head to jamb. Include hinge mortise, reinforcement and grout guard in one rabbet, and glazing stop applied as specified in the opposite rabbet. Apply glazing stop in both head and jamb section to show their intersection.

Fabricate all samples for submission such that they are of the production type and represent in all respects the minimum quality of work to be furnished by the manufacturer. Do not fabricate any work represented by the samples until the samples are approved, and any degradation of fabrication quality compared to the samples is cause for rejection of the work.

C. Test Report

Submit to the Architect upon request, ten (10) days prior to bid date, an independent testing laboratory report certifying that door and frame assemblies meet the performance requirements of Section 1.05 and are constructed in accordance with Sections 2.01, 2.02 and 2.03 of these specifications. With regard to test reports, comply with requirements outlined in ASTM F1450 and F1592.

D. Do not proceed with fabrication without receipt of approved submittal drawings and approved hardware schedules.

The approved submittal drawings and the approved hardware schedules are the versions that have been provided to the hollow metal manufacturer at the time of release for fabrication. These drawings and schedules are considered part of the project contract documents.

PART 2 - PRODUCTS

2.01 DETENTION SECURITY HOLLOW METAL DOORS

A. Materials

ANSI and ASTM Standards no longer utilize “gage” to define steel thickness. In this Specification, steel is expressed in terms of minimum decimal inch (millimeter) thickness. Dimensions or sizes traditionally expressed in fractional inches are shown in decimal inches (millimeters). HMMA has developed a series of Tables (NAAMM/HMMA-803), included as Appendix 1, to summarize the imperial standards and their corresponding metric values.

1. Manufacture Doors of commercial quality, level, cold-rolled steel conforming to ASTM A 1008 / A1008M CS type B, ASTM A 653/A 653M CS Type B Coating Designation A25 (ZF75) for zinc-coated steel, or hot-rolled steel conforming to ASTM A 1011 / A 1011M CS type B. With regard to the steel quality, do not permit scale, pitting, coil breaks, buckles, waves or other surface blemishes or defects.
2. Interior doors: Provide face sheets of [for Grades 3 and 4; 0.067 in. (1.7 mm)] [for Grades 1 and 2; 0.093 in. (2.3 mm)] minimum thickness.

For interior doors subject to corrosive conditions, it is recommended that zinc coated steel face sheets, as specified in 2.01.A.3, be used.

3. Exterior Doors: Provide face sheets of [for Grades 3 and 4; 0.067 in. (1.7 mm)] [for Grades 1 and 2; 0.093 in. (2.3 mm)] minimum thickness with a zinc coating applied by the hot-dip process conforming to ASTM A 653/A 653M Commercial Steel (CS type B), coating designation A60 (ZF180) or G60 (Z180).
4. For severely corrosive conditions and where specified for individual openings, either interior or exterior: Provide face sheets and components of stainless steel conforming to ASTM A 666, Type [304] [316]. Provide finishes for steel stiffened stainless steel detention doors that comply with ANSI/NAAMM HMMA 866, required polish not to exceed #4.

If the Architect determines that zinc coated components for zinc coated face sheets and stainless steel components for stainless steel face sheets are needed in addition to zinc coated or stainless steel face sheets, 2.01.A.3 and 2.01.A.4 are the appropriate locations to specify that requirement.

B. Construction:

1. Fabricate all doors of the types, sizes and construction in accordance with these specifications, and meet the performance requirements of Section 1.05, where applicable. Alternate materials and methods of construction which meet the aforementioned performance criteria are permitted.
2. Join the vertical edges of door face sheets by a continuous weld extending the full height of the door.

See “Weld, Continuous” and “Welded, Continuously” in the Glossary of Terms for Hollow Metal Doors and Frames, ANSI/NAAMM HMMA 801.

3. Fabricate doors such that their nominal door thickness is 2 in. (50.8 mm) to accommodate detention hardware. Fabricate doors neat in appearance and free from warp or buckle. Form edge bends true and straight and of minimum radius for the thickness of material used.
4. Stiffen the door using continuous vertically formed steel sections spanning the full thickness of the interior space between door faces. Fabricate these stiffeners as follows:
 - a. 0.042 in. (1.0 mm) minimum thickness, spaced so that the vertical interior webs are no more than 4 in. (102 mm) apart and securely fastened to both face sheets by spot welds spaced a maximum of 3 in. (76 mm) o.c. vertically. Fill the spaces between stiffeners with fiberglass or mineral rock wool batt-type material.
 - b. As an acceptable option provide a welded-in-place structurally shaped steel core. Provide this core with vertical webs that are spaced not more than 4 in. (102 mm) apart, and which

span the full thickness of the interior space between door face sheets. Install this core such that it extends continuously over the inside width and height of the door, and is securely fastened to both face sheets by spot welds spaced a maximum of 3 in. (76 mm) o.c. vertically. Fill internal hollow spaces with fiberglass or mineral rock wool batt-type material.

5. Reinforce the vertical edges using a continuous steel channel, not less than 0.123 in. (3.1 mm) thickness extending the full height of the door. Close the top and bottom edges with a continuous steel channel, not less than 0.123 in. (3.1 mm) thickness, spot welded to face sheets a maximum of 4 in. (102 mm) o.c. Close the ends using an end channel that is welded to the vertical edge reinforcing channel at all four corners producing a fully welded perimeter reinforcing channel.
6. Fit the top end channel with an additional flush closing channel of not less than 0.053 in. (1.3 mm) material thickness. Weld the flush closing channel in place at the corners and at the center.
 - a. Where specified, seal exterior doors at the top closing channel assembly in order to provide weather resistance.
7. Provide edge profiles on both vertical edges of doors as follows unless hardware dictates otherwise:

Single acting doors - beveled 1/8 in. (3.1 mm) in 2 in. (50.8 mm) profile

Sliding doors or equivalent - square profile

8. Hardware reinforcements and preparations:

- a. Mortise, reinforce, drill, and tap doors at the factory for templated hardware only, in accordance with the approved hardware schedule and templates provided by the hardware supplier. Where non-templated hardware is to be applied, reinforce doors, with all drilling, tapping, and welding done by others in the field.

- b. Minimum material thicknesses for steel hardware reinforcements are as follows:

Full mortise hinges and pivots0.167 in. (4.2 mm)

Surface applied maximum security hinges0.214 in. (5.4 mm)

Strikes0.167 in. (4.2 mm)

Slide device hanger attachment - per device manufacturer's recommendations

Lock fronts, concealed holders, or surface mounted closer.....0.093 in. (2.3 mm)

All other surface applied hardware0.093 in. (2.3 mm)

- c. In cases where power operated hardware is required, and where shown on approved submittal drawings or the approved hardware schedule, provide hardware enclosures and/or junction boxes within the door, and interconnect said enclosures and junction boxes using UL certified 0.5 in. (12 mm) minimum diameter conduit and connectors. Also, where shown on the approved submittal drawings, provide junction boxes with access plates to facilitate the proper installation of wiring. Fabricate access plates using the same material and material thickness as the face sheet and fasten with not less than four (4) 1/4 - 20 or 1/4 - 28 tamper resistant security screws, not to exceed 6 in. (152 mm) o.c.

9. Glazing moldings and stops:

- a. Where specified or scheduled, provide doors with steel moldings to secure glazing materials furnished and installed in the field by others in accordance with glazing sizes and thicknesses shown on contract documents.
- b. Fabricate fixed glass molding using not less than 0.093 in. (2.3 mm), and spot weld molding to both face sheets 3.0 in. (76 mm) o.c. maximum.
- c. In glass openings where non-security glazing is specified or scheduled, fabricate removable glazing stops using pressed steel channel not less than 0.067 in. (1.7 mm) thickness with tight fitting butt or mitered corner joints, and secure glazing stops with #8-32 countersunk, tamper resistant security screws located 2 in. (50.8 mm) maximum from each end and 9 in. (228 mm) o.c. maximum.
- d. In glass openings where security glazing is specified or scheduled, and where shown on the approved submittal drawings, provide pressed steel angle glazing stops, not less than .093 in. (2.3 mm) thickness. Miter or notch angle stops such that they are tight fitting at the corner joints and secure in place using 1/4 - 20 or 1/4 - 28 button head tamper resistant security screws spaced 2 in. (50.8 mm) maximum from each end and 6 in. (152 mm) o.c. maximum. Provide the glazing stop system such that it satisfies the performance criteria in Section 1.05.B.

It is recommended that view window stop heights be specified to provide 1 in. (25.4 mm) glass engagement.

Advisory: It is not advisable to locate glass preparations in close proximity to hardware preparations at the door edge since this can be detrimental to door stiffness.

- e. Treat metal surfaces to which removable glazing stops are applied and the inside of the removable glazing stops for maximum paint adhesion and coat with a rust inhibitive primer prior to installation in the door. Glazing stops fabricated from zinc-coated steel conforming to ASTM A 653/A 653M, A25 (ZF75) for interior doors, A60 (ZF180) for exterior openings need not be primed on the inside.
10. Provide louvers of the welded inverted "V" or "Y" type construction which provide free air delivery as specified. Fabricate the louver opening such that it is flush, using interior channels 0.093 in. (2.3 mm) minimum thickness, securely welded to the inside of both face sheets. Reinforce rectangular louvers exceeding 18 in. (457 mm) in width at their midpoints—using a vertical rectangular steel bar at least 0.25 in. x 1.50 in. (6.4 mm x 38 mm) or a vertical round steel bar at least 0.75 in. (19 mm) diameter. Fabricate the vanes using not less than 0.093 in. (2.3 mm) material thickness and space the vanes so that no rigid flat instrument can be passed through them. Provide insect screens and flattened expanded metal not less than 0.093 in. (2.3 mm) material thickness on louvered doors in exterior locations where shown on contract documents. Louvers of other designs which meet the performance requirements in Section 1.05.A, "Door Impact Test", can be qualified for this application.
11. Provide speaking devices with a rectangular pattern of round holes, no more than 0.25 in. (6.3 mm) dia., in both face sheets directly across from each other. Fabricate the hole pattern with a minimum size of 1 in. (25 mm) high x 4 in. (101 mm) wide with holes spaced no more than 1 in. (25 mm) o.c. vertically and horizontally. Baffle the interior of the door between the rectangular hole patterns using pressed steel sections, not less than 0.067 in. (1.7 mm), so that no objects can be passed through.
12. Food Pass / Cuff Port Openings:
- a. Fabricate the food pass / cuff port opening flush using interior channels 0.093 in. (2.3 mm) minimum thickness, that are securely welded to both face sheets. Continuously weld the four corner seams and dress visible welds smooth. Construct the finished opening such that it cannot be dismantled or otherwise affected by tampering or scraping.
 - b. Construct the food pass / cuff port shutter from two 0.123 in. (3.1 mm) thickness steel plates spot welded together to produce an inset fit that, when closed, will prevent tampering with the lock and hinges.

- c. Treat the shutters for maximum paint adhesion and apply a shop coat of rust inhibitive primer. Ship them separately for installation in the field by others.
13. Swinging and Sliding Shutters for View Ports and Speaking Devices:
- a. Fabricate swinging four-sided rectangular pan shaped shutters for view port and speaking devices from 0.093 in. (2.3 mm) minimum thickness steel sheet, and with 1.0 in. (25.4 mm) minimum flange depths. Continuously weld all corner seams and dress them smooth. Mount the shutter on the surface of doors using a continuous hinge having leaves of the same material thickness as the shutter and position the shutter such that it covers the view port or speaking device symmetrically. Attach hinge leaves to the shutter and to the surface of the door using 1/4-20 security screws or plug welds spaced 1 in. (25.4 mm) minimum from each end and 4 in. (102 mm) O.C. minimum. Finish all plug welds smooth. Weld and finish both ends of the hinge such that the hinge pin cannot be removed. Install a pull and latch or lock as specified on the approved submittal drawings or hardware schedule.
 - b. Fabricate sliding flat shutters and horizontal upper and lower tracks from 0.093 in. (2.3 mm) minimum thickness steel sheet. Mount the tracks to the surface of the door such that the shutter slides smoothly and when shut covers the view port or speaking device symmetrically. Line the track with vinyl or other material that provides for smooth sliding operation and that prevents binding or sticking. Weld both ends of both tracks such that the shutter cannot be removed. Install a pull and latch or lock as specified on the approved submittal drawings or hardware schedule.
 - c. Treat the shutters for maximum paint adhesion and apply a shop coat of rust inhibitive primer.

2.02 DETENTION SECURITY HOLLOW METAL PANELS

- A. Fabricate Hollow metal panels from the same materials and using the same construction finish as specified in Sections 2.01 and 2.06.
- B. Meet performance criteria set forth in Section 1.05.B of this Specification.

2.03 DETENTION SECURITY HOLLOW METAL FRAMES

A. Materials

1. Construct frames from cold rolled steel conforming to ASTM A 1008 / A1008M CS Type B, ASTM A 653/A 653M CS Type B Coating Designation A25 (ZF75) for zinc-coated steel, or hot rolled, pickled, and oiled (HRPO) steel conforming to ASTM A 1011 / A 1011M CS Type B. With regard to steel quality do not permit scale, pitting, coil breaks or other surface defects.
2. Interior openings: Fabricate frame sections using [for Grades 3 and 4; 0.067 in. (1.7 mm)] [for Grades 1 and 2; 0.093 in. (2.3 mm)] minimum material thickness.

For interior areas subject to corrosive conditions, it is recommended that zinc coated frames as specified in 2.03 A.3 be used.
3. Exterior openings: Fabricate frame sections using [for Grades 3 and 4; 0.067 in. (1.7 mm)] [for Grades 1 and 2; 0.093 in. (2.3 mm)] minimum material thickness and fabricate from steel having a zinc coating applied by the hot-dip process conforming to ASTM A 653/A 653M Commercial Steel (CS Type B), coating designation A60 (ZF180) or G60 (Z180).
4. Where specified for severely corrosive conditions and where specified for individual openings, either interior or exterior: Fabricate frame sections using [0.067 in. (1.7 mm)] [0.093 in. (2.3 mm)] minimum thickness. Fabricate frame sections and components using stainless steel conforming to ASTM A 666, Type [304] [316]. Regarding finishes for stainless steel detention frames, comply with ANSI/NAAMM HMMA 866, required polish not to exceed #4.

B. Construction:

1. Fabricate all frames, with the exception of cased openings such as for sliding doors, with integral stops and fabricate as welded units of the sizes and types shown on approved submittal drawings. Construct frames in accordance with these specifications and meet performance criteria specified in Sections 1.05.A and 1.05.B where applicable. Alternate materials and methods of construction which meet the aforementioned performance criteria are permitted.
2. Finish the work neat in appearance, square, and free of defects, warps, and buckles. Form pressed steel members straight and of uniform profile throughout their lengths.
3. Fabricate jamb, header, mullion, and sill profiles in accordance with the frame schedule and as shown on the approved submittal drawings.
4. Close contact edges of all corner joints tight with faces mitered and stops either butted or mitered. Continuously weld corner joints and the use of gussets or splice plates are not acceptable. Refer to Figure 4.

For detailed information on continuously welded corner joints, see Tech Note HMMA-820 TN02-XX.

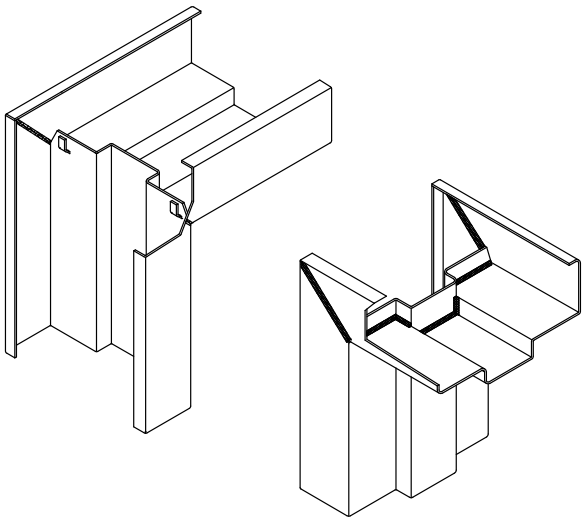

BUTTED AND FACE WELDED JOINTS

CONTINUOUS WELD CORNER JOINT

NOTE: Joint design may vary; see HMMA-820, "Hollow Metal Frames" for representative corner joint details

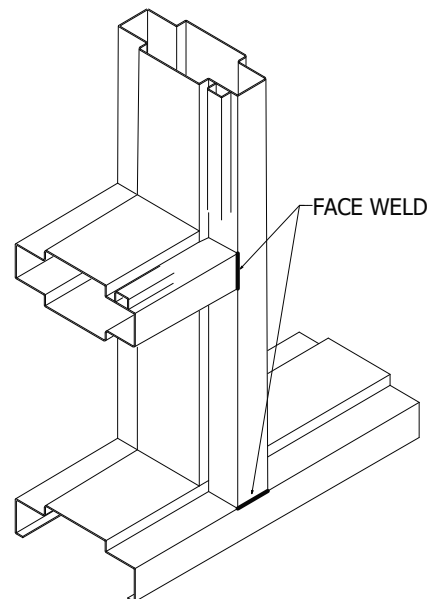

**Figure 4
Example Weld Details**

5. Continuously weld all other face joints and finish them smooth.
6. Provide minimum height of stops in door openings of 0.625 in. (15.8 mm). Provide height of stops on security glazing or panel openings as shown on approved submittal drawings. Cap cut-off stops, where specified at 45 degrees or 90 degrees at heights as shown on approved submittal drawings and fabricate jamb joints below cut-off stops such that they are tight fitting, welded and ground smooth so that there are no visible seams.

In some applications, 3/4 in. (19 mm) frame stops are used with 2 in. (50.8 mm) thick doors.

7. When shipping limitations or site access so dictate, or when advised by the contractor responsible for installation, fabricate frames for large openings in sections designated for assembly in the field by others. Install alignment plates or angles at each joint. Fabricate such components using the same material and material thickness as the frame. Provide field joints in accordance with approved submittal drawings. Field joints are welded and finished by others.
8. Fabricate frames for multiple openings such that they have mullion members which, after fabrication, are closed tubular shapes conforming to profiles shown on approved submittal drawings, and which have no exposed visible seams or joints. Continuously weld all joints between faces of abutted members and finish them smooth. Weld all joints between stops of abutted members along the stop and leave them neat and uniform in appearance. It is the responsibility of the installation contractor to provide for welding and finishing of all field joints between faces of abutted members.

9. Hardware Reinforcements and Preparation:

- a. Mortise, reinforce, drill, and tap frames at the factory for all templated hardware only, in accordance with the final approved hardware schedule and templates provided by the hardware supplier. Reinforce where non-templated hardware is to be applied, with all drilling, tapping, and welding being done by others in the field.

b. Minimum material thickness of steel hardware reinforcements are as follows:

Hinges and pivots	0.167 in. x 1.5 in. x 10 in. length (4.2 mm x 38 mm x 254 mm)
Strikes	0.167 in. (4.2 mm)
Closers	0.167 in. (4.2 mm)
Flush bolts	0.167 in. (4.2 mm)
All other surface applied hardware	0.093 in. (2.3 mm)

- c. In cases where power operated hardware is required, and where shown on approved submittal drawings or approved hardware schedule, provide hardware enclosures and junction boxes, and interconnect said enclosures and junction boxes using UL approved 0.5 in. (12 mm) diameter minimum conduit and connectors. Where shown on contract documents, provide junction boxes with access plates to facilitate the proper installation of wiring. Fabricate access plates using the same material and material thickness as the frame and fasten with not less than four (4) 1/4-20 or 1/4-28 tamper resistant security screws, not to exceed 6 in. (152 mm) o.c.

10. Floor Anchors:

- a. Where applicable, provide floor anchors with two (2) holes for fasteners and fasten floor anchors inside jambs with at least four (4) spot welds per anchor or 1/2 in. (13 mm) fillet welds each side.

- b. Where so scheduled, fasten adjustable floor anchors, providing not less than 2 in. (50.8 mm) height adjustment, in place with at least four (4) spot welds per anchor or 1/2 in. (13 mm) fillet welds each side.
- c. Fabricate floor anchors using the same material thickness as frame.

11. Jamb Anchors:

a. Anchor Spacing

The number of anchors provided on each jamb are as follows:

Borrowed lite frames - 2 anchors plus 1 for each 18 in. (457 mm) or fraction thereof over 36 in. (914 mm), spaced at 18 in. (457 mm) maximum between anchors.

Door frames - 2 anchors plus 1 for each 18 in. (457 mm) or fraction thereof over 54 in. (1372 mm), spaced at 18 in. (457 mm) maximum between anchors (fire ratings can require additional anchors)

b. Masonry Type

In frames for installation in masonry walls, provide adjustable jamb anchors of the strap and stirrup type made from the same material thickness steel as frame. Straps shall be no less than 2 in. x 10 in. (50.8 mm x 254 mm) in size, corrugated and/or perforated.

c. Embedment Masonry Type

- i. In frames for installation in pre-finished masonry or concrete openings provide removable faces at the jambs, and 0.187 in. x 2 in. x 2 in. (4.7 mm x 50.8 mm x 50.8 mm) angle anchors 4 in. (102 mm) long spaced as described in Section 2.03.B.10.a. Locate the frame anchors to coincide with matching embedded anchors to be provided for installation in the wall.
- ii. Fabricate embedded wall anchors such that they consist of a 0.187 in. x 4 in. wide x 6 in. long (4.7 mm x 102 mm wide x 152 mm long) plate with 0.187 in. x 2 in. x 2 in. (4.7 mm x 50.8 mm x 50.8 mm) angle anchors 4 in. (102 mm) long welded in place at locations to match angle anchors in frames. Provide the embedded plate with two (2) #4 re-bar wall anchors 10 in. (254 mm) long minimum, with 2 in. (50.8 mm) x 90 degree turn down on ends continuously welded in place and spaced as described in Paragraph 2.03.B.10.a. Prime paint embedments in accordance with Section 2.06.
- iii. Fasten angle anchors to jamb and to embedded plate with two (2) 1 in. (25.4 mm) long arc welds at each end of the anchor. Ship anchors loose for installation in the field.
- iv. Provide the complete anchorage system such that the jamb faces can be removed from the frames in the field by the contractor responsible for installation, and the frames can be moved into the opening. Using the 0.187 in. x 2 in. x 2 in. x 4 in. (4.7 mm x 50.8 mm x 50.8 mm x 102 mm) long angles, the installer welds one edge of the angle to the embedded anchor and the other edge to the frame mounted anchor forming a rigid connection between the frame and the embedded plate. The procedure is repeated for all anchor positions. The installer field welds all anchors and installs the jamb faces in place. Provide embedment anchoring details on approved submittal drawings.

d. Expansion Bolt Type

- i. Prepare frames for installation in existing masonry or concrete walls for expansion bolt type anchors. Fabricate the preparation such that it consists of a countersunk hole for a

0.5 in. (12.7 mm) diameter bolt and a spacer from the unexposed surface of the frame to the wall welded within the jamb profile. Space the preparations as described in Section 2.03.B.10.a. Fasteners for such anchors are provided by others.

- ii. After sufficient tightening of the bolt, it is the responsibility of the installation contractor to weld the bolt head so as to provide a non-removable condition, and to also, grind and dress the welded bolt head, and to finish it smooth.
 - e. Construct frames to be installed in pre-finished concrete, masonry, or steel openings, and provide them with anchoring systems of suitable design as shown on the approved submittal drawings.
12. Provide grout guards at all hardware preparations, glazing stop screws and silencer preparations on frames to be set in masonry or concrete openings. Fabricate grout guards sufficient to protect preparations from grout of a 4 in. (102 mm) maximum slump consistency which is hand troweled in place. If pump grout that exhibits slump values of higher than 4 in. (102 mm) is used, it is the responsibility of the contractor to take additional precautions to seal grout guards to prevent leakage and to brace frame sections to prevent deformation. (Ref. HMMA-820 TN01-03, "Grouting of Hollow Metal Frames").
13. Provide all door openings with two (2) temporary steel spreaders welded to the bottom of the jambs or mullions to serve as bracing during shipping and handling. It is the responsibility of the installation contractor to finish, and touch-up marks and damage caused by spreader removal.
14. Removable glazing stops:
- a. In openings where non-security glazing is specified, fabricate removable channel type glazing stops using the same material type as frame, not less than 0.067 in. (1.7 mm) thickness, butted at corner joints and secured to the frame using a minimum of #8-32 countersunk tamper resistant security screws, spaced 2 in. (50.8 mm) maximum from each end and 9 in. (228 mm) o.c. maximum.
 - b. In openings where security glazing is specified and where shown on the approved submittal drawings, provide pressed steel angle glazing stops, not less than 0.093 in. (2.3 mm) thick. Miter or notch angle stops tight fitting at the corner joints and secure in place using 1/4 - 20 or 1/4 - 28 tamper resistant security screws spaced 2 in. (50.8 mm) maximum from each end and 6 in. (152 mm) o.c. maximum. Provide glazing stop system that satisfies the performance criteria in Section 1.05 A.

It is recommended that view window stop heights be specified to provide 1 in. (25.4 mm) glass engagement.
 - c. Treat the frame section underneath the glazing stops and the inside of the glazing stops for maximum paint adhesion and coat with a rust inhibitive primer prior to installation in the opening. Glazing stops fabricated from zinc-coated steel conforming to ASTM A 653/A 653M, A25 (ZF75) for interior frames, A60 (ZF180) for exterior openings need not be primed on the inside.

2.04 MANUFACTURING TOLERANCES

The manufacturer of hollow metal doors and frame product is responsible only for the manufacturing tolerances listed in 2.04.A. The final clearances and relationships between door and frame depend on the setting of the frame (see Figure 4), and the hanging and adjustment of the door and hardware. See Sections 3.02 and 3.03.

A. Maintain manufacturing tolerances within the following limits and in accordance with ANSI/NAAMM HMMA 841:

1. Frame Product for Singles or Pairs of Doors

- a. Width, measured between rabbets at the head: nominal opening width + 1/16 in. (+ 1.5 mm), - 1/32 in. (- 0.8 mm)
- b. Height (total length of jamb rabbet): nominal opening height + 1/16 in. (+ 1.5 mm), - 1/32 in. (- 0.8 mm)
- c. Cross sectional profile dimensions (see Figure 5):
 - i. Face ± 1/32 in. (0.8 mm)
 - ii. Stop ± 1/32 in. (0.8 mm)
 - iii. Rabbet ± 1/32 in. (0.8 mm)
 - iv. Depth ± 1/16 in. (1.5 mm)
 - v. Throat ± 3/32 in (2.3 mm)

Frame product overlapping walls to have throat dimension 1/8 in. (3.1 mm) greater than dimensioned wall thickness to accommodate irregularities in wall construction.

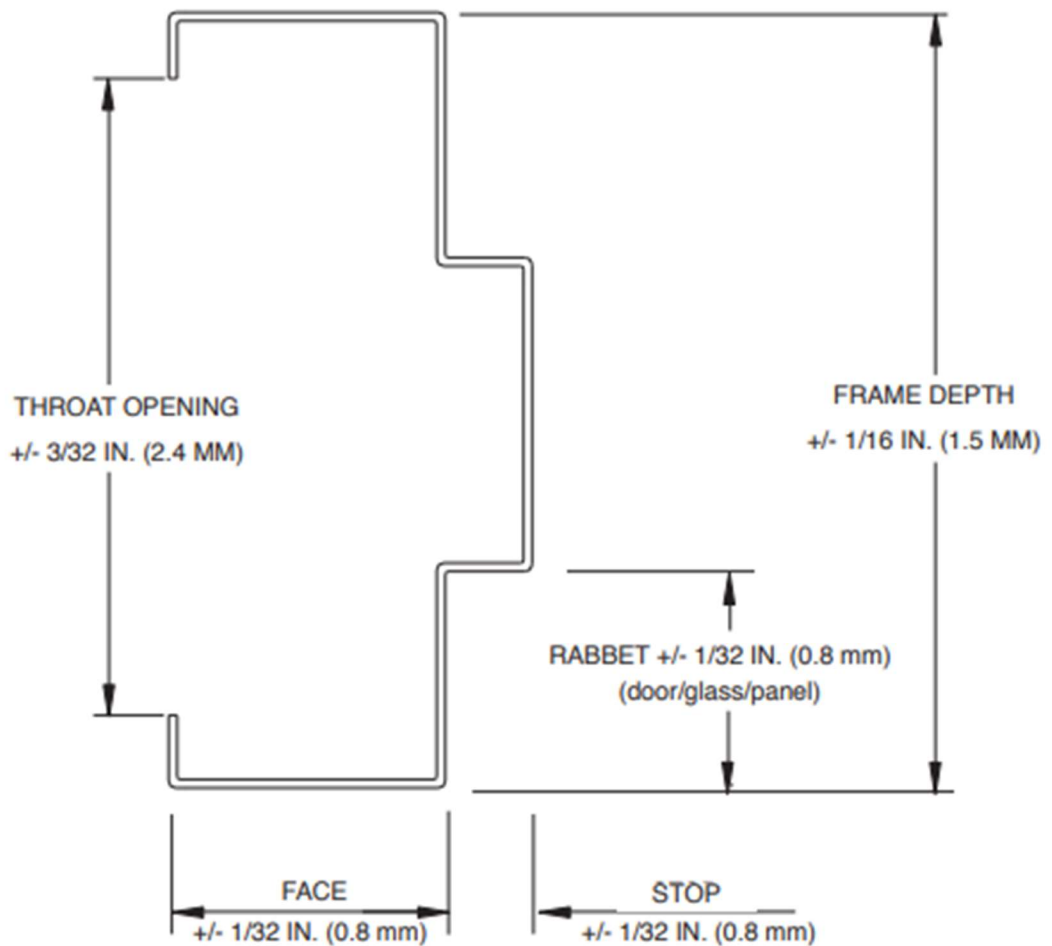

Figure 5
Section Profile Tolerances

2. Doors

Tolerances for actual hollow metal door size are as follows:

- a. Width $\pm 3/64$ in. (1.2 mm)
- b. Height $\pm 3/64$ in. (1.2 mm)
- c. Thickness $\pm 1/16$ in. (1.5 mm)
- d. Perimeter Flatness 1/16 in. (1.5 mm) maximum
- e. Surface Flatness 1/8 in (3.1 mm) maximum
- f. Twist 1/16 in. (1.5 mm) maximum
- g. Squareness 1/16 in. (1.5 mm) maximum

Surface flatness is applicable to doors up to 48" in width and 120" in height. Doors that exceed these measurements will possibly exceed this tolerance and are not considered defective as long as they operate/function properly.

Hollow metal doors are undersized to fit the frame's door opening. Edge clearances are based upon individual manufacturer's designs.

3. Hardware

- a. Cutouts Template dimensions +1/64 in. (0.4 mm), - 0
- b. Location $\pm 1/32$ in. (0.8 mm)
- c. Between hinge centerlines $\pm 1/64$ in (0.4 mm)
- d. Face cutout for hinges + 1/16 in.(1.5 mm) – 0
- e. Mortise depth of reinforcement $\pm 1/64$ in (0.4 mm)

These tolerances provide a reasonable guideline for manufacturing of hollow metal products. However, it should be noted that the cumulative effect of manufacturing tolerances at or near their maximum levels could have an effect on operating clearances. Tolerance buildup occurs when several tolerances are at or near their maximums. Care should be taken to keep each of these tolerances as close to zero as possible.

2.05 HARDWARE LOCATIONS

- A. The location of hardware on doors and frame products shall be as listed below. All dimensions, except the hinge locations, are referenced from the floor as defined in Section 3.03.B.3.

When hollow metal frame products are specified for use with doors to be furnished by others, hardware preparations on the doors are normally governed by the location on the frames as stated, in 2.05 A.

1. Hinges

- a. Top 5 in. (127 mm) from underside of frame rabbet at door opening to top of hinge
- b. Bottom 10 in. (254 mm) from floor to bottom of hinge
- c. Intermediate Equally spaced between top and bottom hinges
- d. On dutch doors 5 in. (127 mm) from underside of frame rabbet at door opening to top of upper hinge; 10 in. (254 mm) from floor to bottom of lower hinge; and 5 in. (127 mm) from split line to top and bottom of lower and upper intermediate hinges, respectively

- | | |
|-----------------------------------|---|
| 2. Detention Locks | 38-42 in. (965-1066 mm) to lockbolt centerline |
| Lever/ Knob Locksets..... | 38-42 in. (965-1066 mm) to centerline of strike |
| 3. Deadlocks..... | 46 in. (1168 mm) to centerline of cylinder |
| 4. Exit hardware | Centerline of cross bar as shown on hardware template or as shown on approved contract documents. |
| 5. Door pulls | 42-46 in. (1066-1168 mm) to center of grip |
| 6. Push/pull bars..... | 42-46 in. (1066-1168 mm) to centerline of bar |
| 7. Hospital latch arm pulls | According to mfr. templated information |
| 8. Push plates..... | 42-46 in. (1066-1168 mm) to centerline of plate |
| 9. Roller latches..... | 46 in. (1168 mm) to centerline of latch |
| 10. Intercoms | 48 in. (1219 mm) to centerline of intercom pushbutton |

The hardware locations listed in this specification reflects HMMA's 830, "Hardware Selection for Hollow Metal Doors and Frames" and 831, "Recommended Hardware Locations for Hollow Metal Doors and Frames". However, specific hardware and/or individual door frame manufacturers' designs may require different locations.

It is the responsibility of the architect to notify door and frame manufacturers during the approval process of any required changes to the standard locations listed above in order to comply with building codes and ADA or other requirements.

2.06 FINISH

- A. After fabrication, fill and sand all tool marks and surface imperfections as required to make face sheets, continuously welded vertical door edges and weld joints free from irregularities and dressed smooth.
- B. After appropriate metal preparation to ensure maximum paint adhesion, provide a factory applied rust inhibitive direct to metal (DTM) primer coating to all exposed surfaces of door and frame product manufactured from cold-rolled, hot-rolled, or A60 (ZF180) zinc-coated. Meet the performance requirements of Section 1.05.C.
- C. All primer must be cured prior to shipment.

PART 3 – EXECUTION

3.01 SITE STORAGE AND PROTECTION OF MATERIALS

Correct site storage and protection are essential to proper performance of doors and frame product. The requirements for proper storage are given in the following Section. However, it is important to recognize that these are not the responsibility of the hollow metal manufacturer. For this reason the requirements for storage and protection of hollow metal doors and frame product should be included in the Section of the specification where installation work is specified. For additional information regarding installation see NAAMM HMMA 840, "Guide Specification for Installation and Storage of Hollow Metal Doors and Frames".

- A. Responsibilities of the contractor responsible for receiving hollow metal door and frame product;
1. Remove wraps or covers upon delivery at the building site and ensure that any scratches or disfigurement caused by shipping or handling are promptly cleaned and touched up with a rust inhibitive 'Direct to Metal' (DTM) primer.
 2. Ensure that materials are properly stored on planks or dunnage in a dry location. Store doors and frame product in a vertical position, spaced by blocking. Figure 6 illustrates recommended storage positioning. Cover materials to protect them from damage but in such a manner as to permit air circulation.

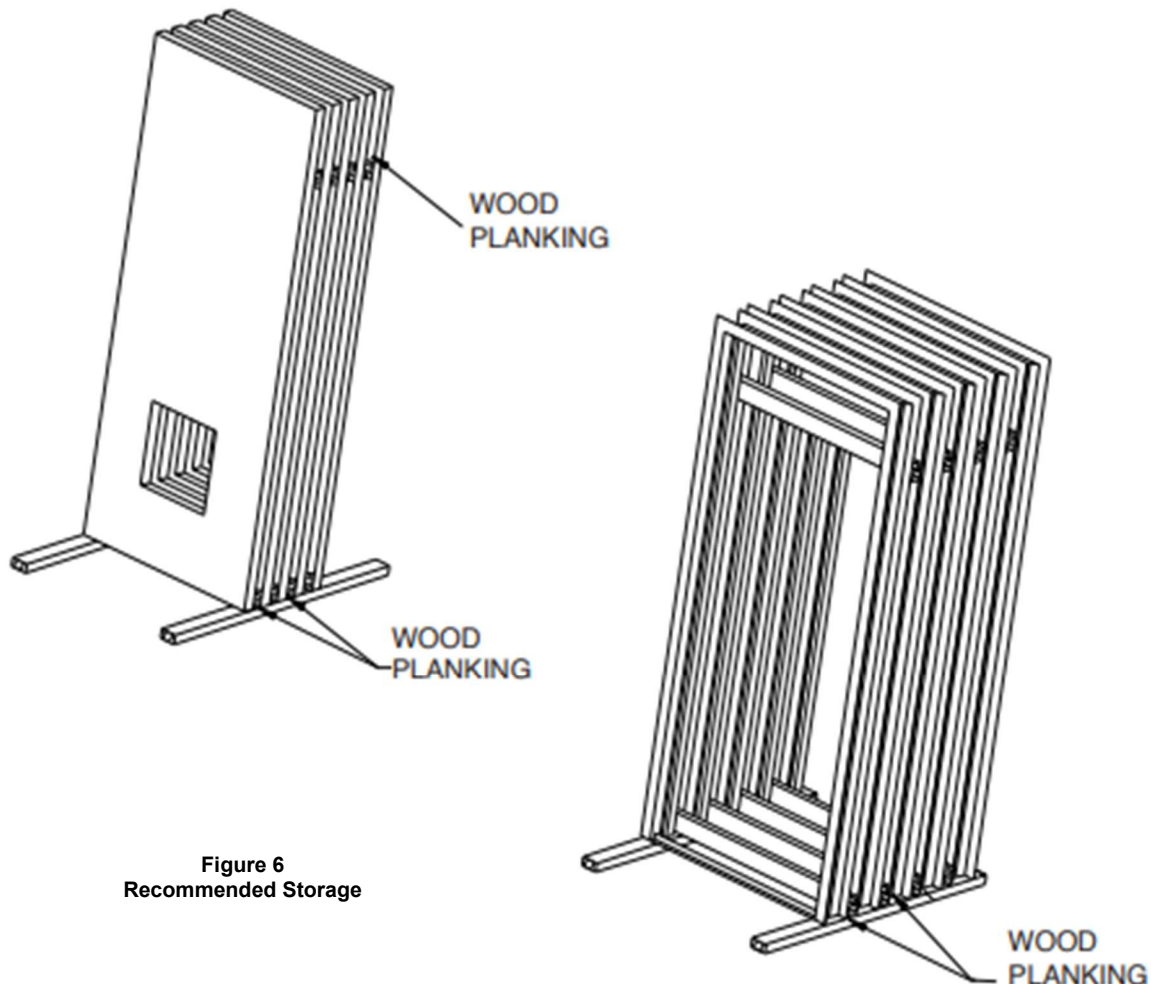

Figure 6
Recommended Storage

3.02 INSTALLATION

Correct installation is essential to the proper performance of doors and frame product. The requirements for proper installation are given in the following Sections. However it is important to recognize that installation is not the responsibility of the hollow metal manufacturer. For this reason the requirements for installation should be included in Sections 03 30 00, 04 20 00, 06 11 00 and/or 09 20 00 of the project specifications, as appropriate. For additional information see NAAMM HMMA 840, "Guide Specifications for Installation and Storage of Hollow Metal Doors and Frames"..

The installer is responsible for performing the following:

A. Prior to installation;

1. Check the area of floor on which the frame product is to be installed, and within the path of the door swing, for flatness and correct if necessary.
2. Check doors and frame product for correct size, swing, fire rating and opening number. If product does not comply with contract documents, do not install and contact the supplier.
3. Isolate and protect all interior surfaces of frame product sections to be installed in masonry or concrete walls from grout and antifreeze agents.

The drawbacks and benefits associated with the use of water based masonry grouts, with or without antifreeze agents, should be carefully weighed during the detailing and specification process. Plaster based grouts should not be used. Antifreeze agents can adversely affect metal and all surfaces in contact with grout must be coated with a corrosive resistant material. Refer to NAAMM HMMA Tech Note, HMMA 820 TN01-XX, "Grouting Hollow Metal Frames", included as Appendix 2, for further guidance.

4. Remove temporary spreaders.
5. Refinish to match original, any marks caused by spreader removal.

B. During the setting of frame product check and correct as necessary for opening width, opening height, squareness, alignment, twist and plumbness. Maintain installation tolerances within the following limits.

1. Opening Width..... measured from rabbet to rabbet at top, middle and bottom of frame + 1/16 in (1.5 mm), – 1/32 in (0.8 mm)
2. Opening Height.....measured vertically between the frame head rabbet and top of floor or bottom of frame minus jamb extension at each jamb and across the head; + 1/16 in (1.5 mm), – 1/32 in (0.8 mm)
3. Squareness.....measured at rabbet on a line from jamb, perpendicular to frame head; not to exceed 1/16 in (1.5 mm)
4. Alignment.....measured at jambs on a horizontal line parallel to the plane of the face; not to exceed 1/16 in (1.5 mm)
5. Twist..... measured at opposite face corners of jambs on parallel lines perpendicular to the plane of the door rabbet; not to exceed 1/16 in (1.5 mm)
6. Plumbness.....measured at the jambs on a perpendicular line from the head to the floor; not to exceed 1/16 in (1.5 mm)

The above tolerances provide a reasonable guideline for proper installation of hollow metal frame product. However, it should be noted that the cumulative affect of the installation tolerances at or near their maximum levels could result in sufficient misalignment to prevent the door from functioning properly. Installers should be careful not to create a tolerance buildup.

C. The details in Figure 7 illustrate the method of measuring the above specified tolerances.

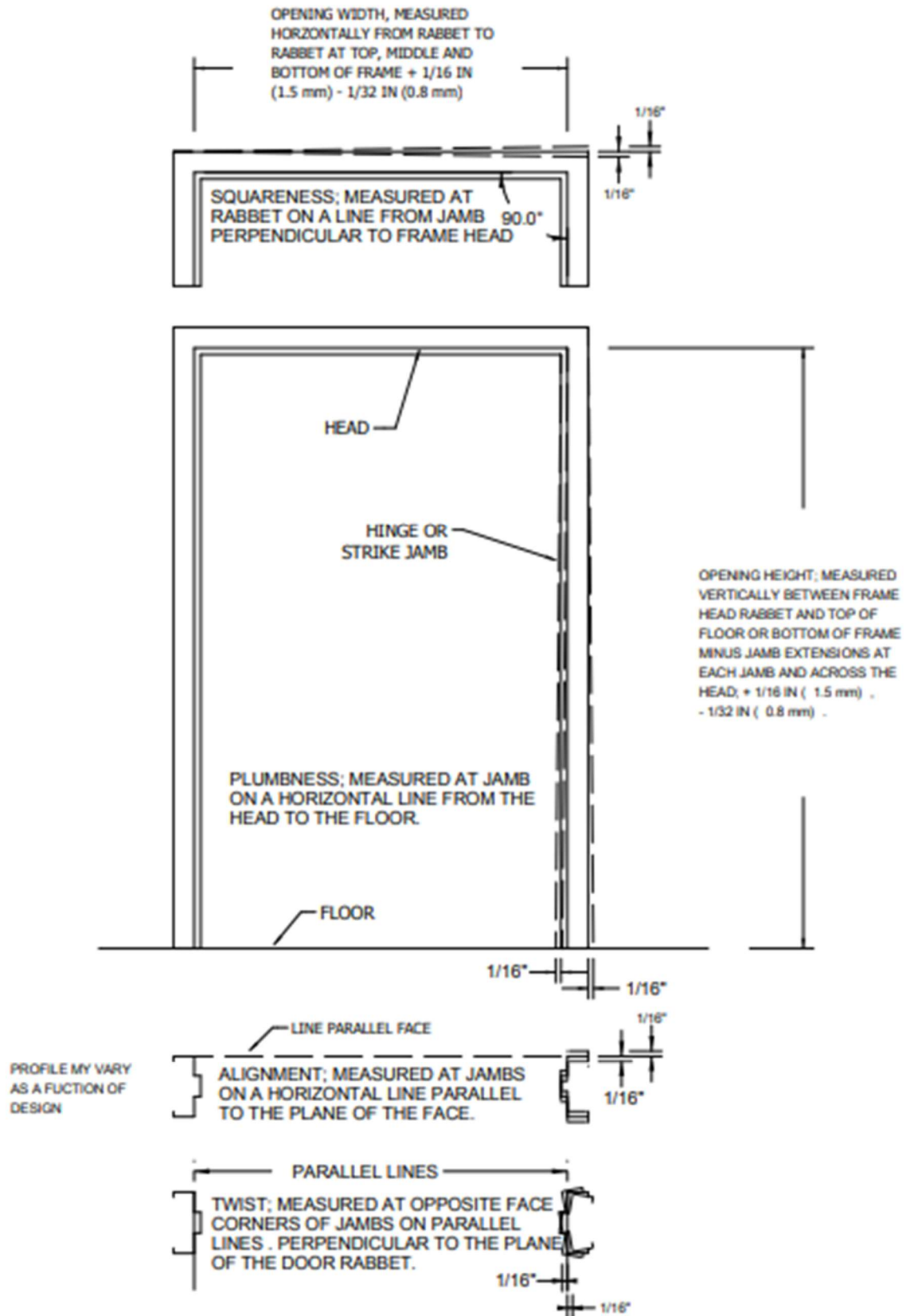

Figure 7
Installation Tolerances

- D. Grout guards and junction boxes are intended to protect hardware mortises and tapped holes from masonry grout of 4 in. (101 mm) maximum slump consistency which is hand troweled in place. If a lighter consistency grout (greater than 4 in. (101 mm) slump when tested in accordance with ASTM C 143/C 143M) is to be used, special precautions must be taken in the field by the installer to protect the aforementioned.
- E. Frame products are not intended or designed to act as forms for grout or concrete. Take precautions otherwise to ensure that frames are not deformed or damaged by the hydraulic forces that occur during this process.
- F. Keep steel surfaces free of grout, tar, and/or other bonding materials or sealers. Promptly clean grout, tar, and/or other bonding materials or sealers off of doors and frame product. If the primer is removed, damaged or negatively affected by this process, promptly finish smooth, clean, treat for maximum paint adhesion and touch up with a rust inhibitive primer comparable to and compatible with the shop applied primer and finish paint specified in Section 09 90 00. All touch-up primer and finish paint must be formulated for Direct to Metal (DTM) application.
- G. Install labeled fire doors and frame product in accordance with the terms of their listings, ANSI/NFPA 80 or the local Authority Having Jurisdiction.
- H. Maintain proper door edge clearances in accordance with Section 3.03, except for special conditions otherwise noted. Where necessary, metal hinge shims, furnished by the installer, are permitted to maintain clearances.
- I. Exposed hollow metal surfaces which have been scratched or otherwise marred during installation, cleaning, and/or field welding, shall promptly be finished smooth, cleaned, treated for maximum paint adhesion and touched up with a rust inhibitive primer comparable to and compatible with the shop applied primer and finish paint specified in Section 09 90 00. All touch-up primer and finish paint must be formulated for Direct to Metal (DTM) application.
- J. Install hardware in accordance with hardware manufacturer's templates and instructions.
- K. Finish paint in accordance with Section 09 90 00.
See NAAMM HMMA 840 TN01-XX, Painting Hollow Metal Products.
- L. Install door silencers.
- M. Install glazing materials in accordance with Section 08 80 00.

3.03 CLEARANCES

- A. Ensure that the edge clearance for swinging hollow metal doors provides for the functional operation of the assembly and does not exceed the following:
 - 1. Between doors and frame product at head and jambs.. 1/8 in (3.1 mm) +/- 1/16" (1.5 mm)
 - 2. Between edges of pairs of doors..... 1/8 in (3.1 mm) +/- 1/16" (1.5 mm)
- B. Clearances for detention sliding doors shall be in accordance with the approved slider device drawings furnished as part of the approved hardware schedule.
- C. Floor clearance for fire rated swinging detention hollow metal doors shall not exceed 3/4" (19.0 mm). Floor clearance shall be provided for the functional operation of all swinging hollow metal doors and shall not be less than 1/8" (3.1 mm).

The architect must define the distance from top of the floor/finished floor to top of floor covering so appropriate undercuts can be provided. Floor/Finish Floor is defined as the top of the concrete or structural slab. HMMA uses the term "top of floor covering" to describe the NFPA term "nominal surface of floor covering". Refer to HMMA's Tech Note, HMMA 810 TN01-XX, "Defining Undercuts", included as Appendix 3 for further guidance.

3.04 JOB SITE DOOR CHECK

At the owner's option, select a door at the job site at random and saw it in half or otherwise take it apart as deemed necessary, for verification that construction is in accordance with these specifications and testing documentation in accordance with Section 1.07.C.

APPENDIX 1

(Not part of the Standard)

NAAMM/HMMA 803-XX - STEEL TABLES

Prior to 1970, sheet steel was referred to by gage. ASTM and ANSI currently do not list gage numbers in their standards. Like many generic terms, gage (or gauge) is ingrained in many vocabularies and is misunderstood as a term for thickness. NAAMM is publishing this minimum thickness table to be used instead of discontinued gage numbers.

The decimal inch values shown were taken from the Underwriters Laboratories, Inc. publication for gage number and equivalent thickness. Corresponding metric values are included for reference purposes only.

MINIMUM THICKNESS (Uncoated Steel Sheet)		
Gage	Decimal Inch	mm
4	0.214	5.43
5	0.199	5.05
6	0.184	4.67
7	0.167	4.24
8	0.152	3.86
10	0.123	3.12
12	0.093	2.36
14	0.067	1.70
16	0.053	1.34
18	0.042	1.06
20	0.032	0.81
22	0.026	0.66
24	0.020	0.50
26	0.016	0.40
28	0.013	0.33

CONVERSION		
Fractional Inch	Decimal Inch	mm
	1.000	25.40
15/16	0.937	23.81
7/8	0.875	22.22
13/16	0.812	20.63
3/4	0.750	19.05
11/16	0.687	17.46
5/8	0.625	15.87
9/16	0.562	14.28
1/2	0.500	12.70
7/16	0.437	11.11
3/8	0.375	9.52
5/16	0.312	7.93
1/4	0.250	6.35
3/16	0.187	4.76
1/8	0.125	3.17
1/16	0.062	1.58

DISCLAIMER

This sheet was developed by representative members of the Hollow Metal Manufacturers Association Division (HMMA) of the National Association of Architectural Metal Manufacturers (NAAMM) to provide their opinion and guidance on minimum thickness and corresponding metric equivalents used for hollow metal doors and frames. This sheet contains advisory information only and is published as a public service by the HMMA Division.

NAAMM AND ITS HMMA DIVISION DISCLAIM ALL LIABILITY OF ANY KIND FOR THE USE,
APPLICATION OR ADAPTATION OF MATERIAL SHOWN ON THIS SHEET

APPENDIX 2

(Not part of the Standard)

GROUTING HOLLOW METAL FRAMES

HMMA-820 TN01-XX

Grout, when used in accordance with industry guidelines can improve frame durability, sound deadening and, depending on wall construction, increases frame anchorage strength. Grouting of the frame does not increase door durability, nor is it required for fire-rated frames. For most commercial applications, grouting of mullions and other closed sections is not recommended.

For applications covered by ANSI/NAAMM HMMA 862, "Guide Specifications for Forced Entry/Bullet Resistant (FE/BR) Security Hollow Metal Doors and Frames" and ANSI/NAAMM HMMA 863, "Guide Specifications for Detention Security Hollow Metal Doors and Frames", the standards require that "frame jambs shall be fully grouted to provide added security protection against battering, wedging, spreading, and other means of forcing open the door".

Grout is a water-based product. If not used properly, it can destroy the opening in a very short time. Grout can be either "mortar", which is a masonry mixture of lime, cement, sand and water, or "plaster", a gypsum-based product.

Plaster grout dries with exposure to air. When a frame member is filled solid with plaster grout, only those areas exposed to air will dry and harden, while the center remains wet (uncured). The water remaining in the plaster grout can rust the frame from the inside.

Mortar grout cures by chemical reaction and hardens throughout. Use mortar grout.

Frames are not designed to act as forms for grout. Grout must have a maximum 4 in. slump and be hand troweled in place. Bracing of the frame may be necessary prior to grouting to prevent sagging of the header or bowing of the jamb due to weight or pressure of the grout. Grout should not be installed after gypsum wallboard is installed, as the liquid within the grout will deteriorate the wallboard.

When dictated by temperatures, anti-freezing agents for mortar may be recommended by specifications. These agents can adversely affect metal and all surfaces in contact with grout must be coated with a corrosion resistant material.

APPENDIX 3

(Not part of the Standard)

DEFINING UNDERCUTS

HMMA-810 TN01-XX

Review of established definitions.

1. **“ACTUAL DOOR HEIGHT”** - The door opening height minus top clearance and undercut.
2. **“DOOR OPENING HEIGHT”** - The distance measured vertically between the frame head rabbet and top of floor or bottom of frame minus jamb extension.
3. **“FINISHED FLOOR”** - See “Floor”
4. **“FLOOR”** - The top of the concrete or structural slab.
5. **“FLOOR CLEARANCE”** - The distance between the bottom of the door and the top of the material directly below the door. This varies with application, such as concrete, any floor covering and/or a threshold.
6. **“FLOOR COVERING”** - Any material applied on top of the floor that extends under the door in its closed position or under the door as it swings to its fully open position.
7. **“UNDERCUT”** - The distance between the bottom of door and the bottom of frame. The formula in which to determine Undercut is derived by adding the total sum of the following (Floor Clearance + Floor Covering Thickness + Threshold Height (assuming the threshold is mounted on top of the floor covering) + Jamb Extensions Height).
8. **“JAMB EXTENSIONS”** - That portion of a jamb or mullion which extends below the level of the floor.

Typically, frames are intended to be installed directly on the floor. When no floor coverings or thresholds are used, the dimension for “Undercut” is the same as for “Floor Clearance”. See Figure A-1.

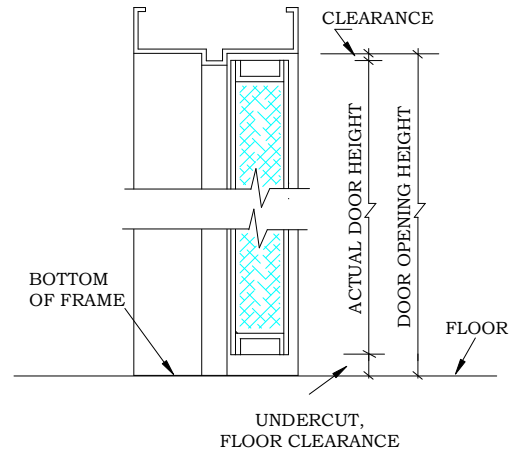

Figure A-1

Floor coverings: such as carpet, resilient or ceramic tile, are typically installed on top of the floor, fitted around the frame, and under the door. In this situation, the formula for figuring Undercut is the total of the Floor Clearance + Floor Covering Thickness. See Figure A-2.

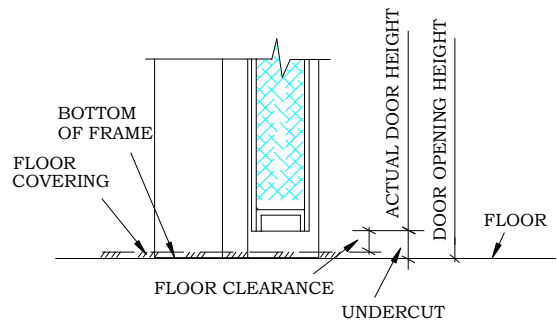

Figure A-2

When a threshold is used, it is installed on top of the floor or floor covering, fitted around the frame and under the door. Again the formula for figuring “Undercut” changes. Undercut is the total of the Floor Clearance + Threshold Height + Floor Covering Thickness. See Figure A-3.

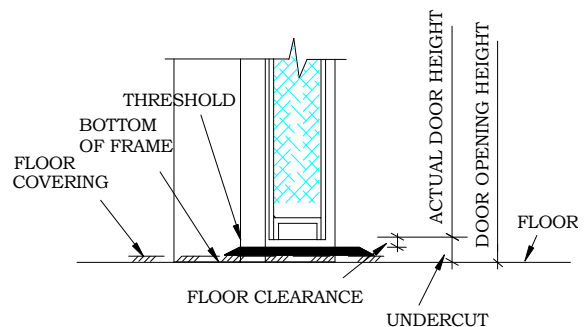

Figure A-3

In situations with specialized floors such as thick ceramic tile or terrazzo, the frame is typically installed prior to the installation of the floor.

One method is to install the frame with adjustable floor anchors or for the frame to be installed on a block or shim. This allows the frame to be positioned, as required, to accommodate the floor height. See Figures A-4a and A-4b. Both illustrate a raised frame condition in which the bottom of frame is positioned to be directly on top of the floor after the floor is installed. In this situation, the dimension measured for Undercut is also the same as Floor Clearance.

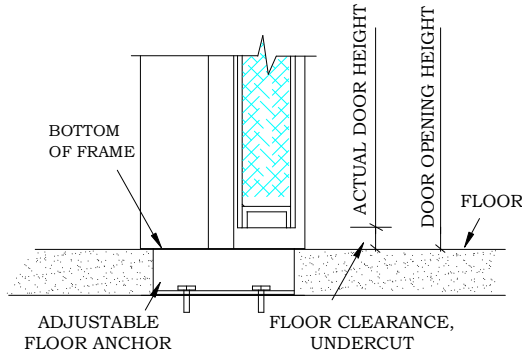

Figure A-4a

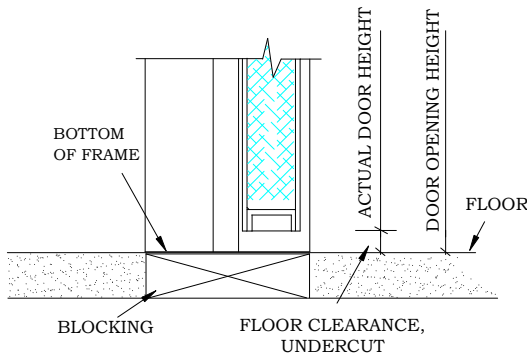

Figure A-4b

Another method, called "below floor installation", is to install the frame directly on the rough slab. After the frame is installed, the floor is then installed around the frame. That portion of the frame is covered by the floor and is called jamb extensions. The formula for figuring "Undercut" is the total of the Floor Clearance + Jamb Extensions. See Figures A-5a and A-5b.

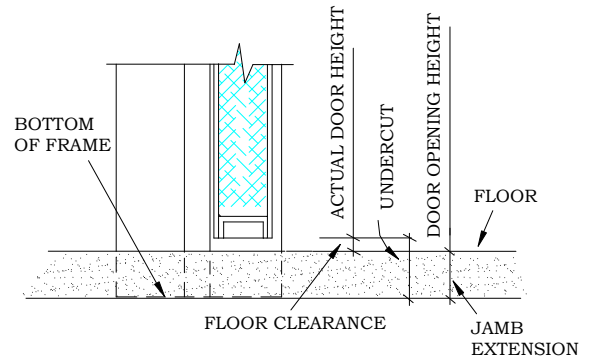

Figure A-5a

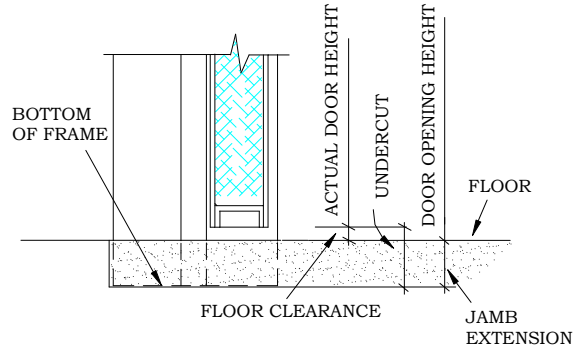

Figure A-5b

The Architect/Designer must be very specific within specifications and contract drawings, which should include detailed drawings illustrating conditions for each floor, including thicknesses and materials. These drawings should designate the height at which the hollow metal frame should be set. Thresholds and hardware items requiring specific floor clearances shall be listed in the hardware schedule, which allows the door and frame manufacturer to properly size each opening.

Within the door and frame industry, both the Hollow Metal Manufacturers Association (HMMA) a division of the National Association of Architectural Metal Manufacturers (NAAMM) and the Steel Door Institute (SDI), publish recommended clearances. In addition, the National Fire Protection Association (NFPA) Publication 80, "Standard for Fire Doors and Fire Windows", regulates the installation and maintenance of labeled openings, and lists several different scenarios consisting of different floor materials and the maximum clearance under the bottoms of doors.

APPENDIX 4

(Not part of the Standard)

STANDARDS DEVELOPMENT ORGANIZATIONS

- ANSI** American National Standards Institute, Inc.
25 West 43rd Street, 4th Floor
New York, NY 10036
Tel: (212) 642-4900
Website: www.ansi.org
- ASTM** ASTM International
100 Barr Harbor Drive
West Conshohocken, PA 19428-2959
Tel: (610) 832-9585
Website: www.astm.org
- ICC** International Code Council
200 Massachusetts Ave. NW
Suite 250
Washington, DC 20001
Tel: 1 (888) 422-7233
Website: www.iccsafe.org
- NAAMM** National Association of Architectural Metal Manufacturers
800 Roosevelt Road
Building C, Suite 312
Glen Ellyn, IL 60137
Tel: (630) 942-6591
Website: www.naamm.org
- NFPA** National Fire Protection Association
1 Batterymarch Park
Quincy, MA 02169
Tel: (617) 770-3000
Website: www.nfpa.org
- UL** UL Solutions Headquarters
333 Pfingsten Road
Northbrook, Illinois 60062
Tel: (847) 272-8800
Website: www.ul.com